

Kalystrus

TABLES

2026

Antonio Citterio



Description

The new Kalystrus table collection explores the theme of monumentality through pure geometries and materials of strong presence. At the heart of the project is the conical form, reinterpreted as a structural element capable of lending the tables a sculptural yet elegant character. The elliptical-top version, available in widths of 300 cm and 350 cm, seats 8-10 people and features two conical legs, a solution that enhances both stability and visual strength. Alongside this is a circular version seating six, a new interpretation of the round table that adopts a single central cone as its base. Offered in one size with a diameter of 160 cm, it provides a convivial solution with balanced proportions. Both versions are available entirely in wood, in a range of finishes - brushed light oak, brushed black oak and wenge - as well as entirely in marble. Marble options include the new polished veined Arabescato, alongside polished white Calacatta and matt or polished black Marquinia, already part of the Maxalto collection. A further option combines a wooden top with marble legs, expressing a measured balance between material richness and proportion, and establishing a strong architectural presence within the domestic space. In this configuration, the conical base is also available in natural travertine marble. The mineral presence of this element naturally complements the wooden finishes of the top, creating a harmonious contrast between warm surfaces and varied textures. With this collection, Maxalto expands its formal repertoire, introducing a new language of assertive volumes and noble materials, interpreted through the design sensibility of Antonio Citterio.

Technical drawings

TKL160

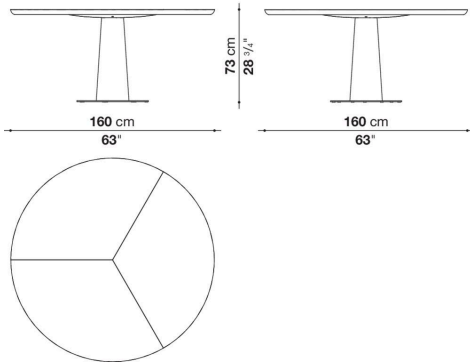

TKL160_M

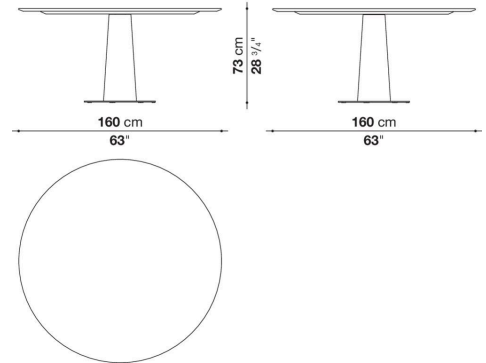

TKL160R_W_M

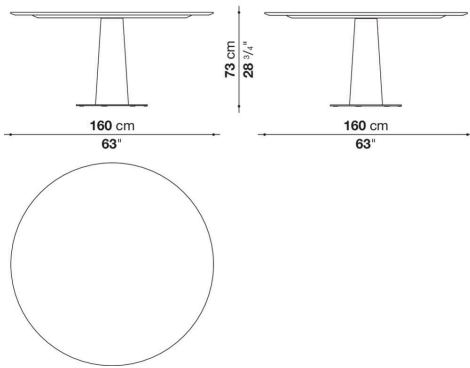

TKL160_MR_MW

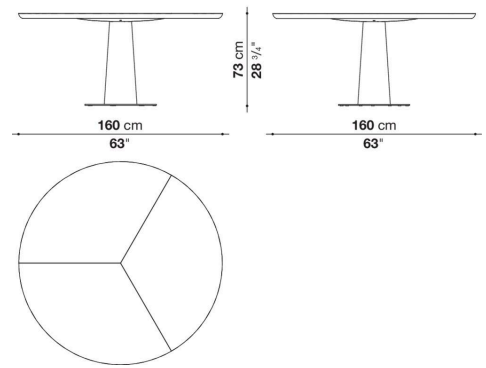

TKL160G

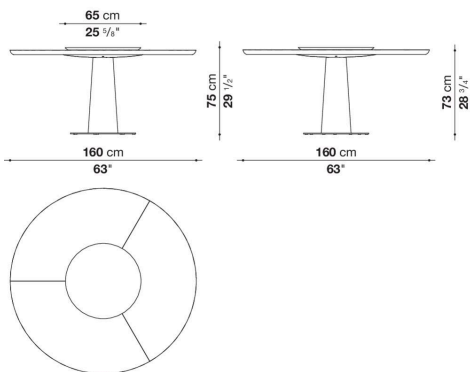

TKL160G_M

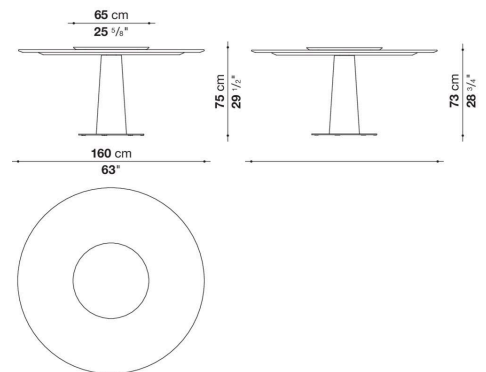

TKL160GR_GW_M

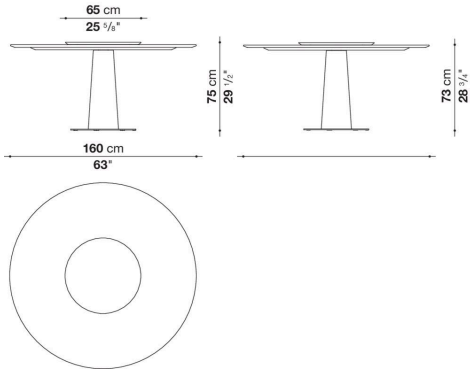

TKL160G_MR_MW

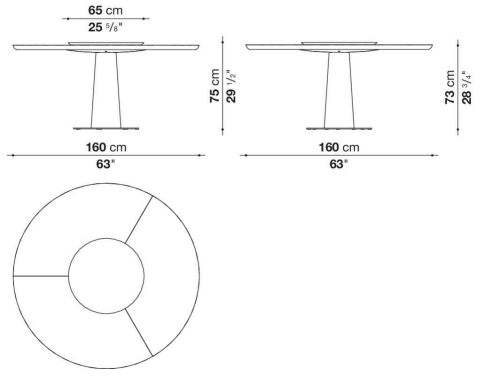

TKL300

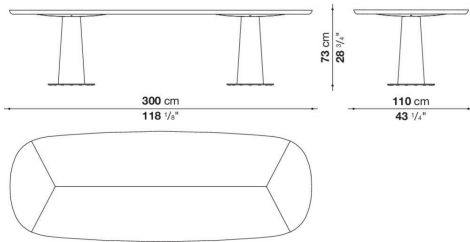

TKL300_M

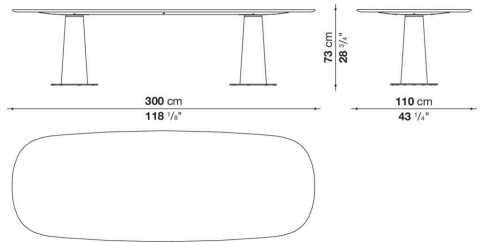

TKL300R_W_M

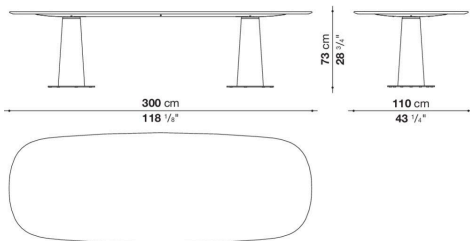

TKL300_MR_MW

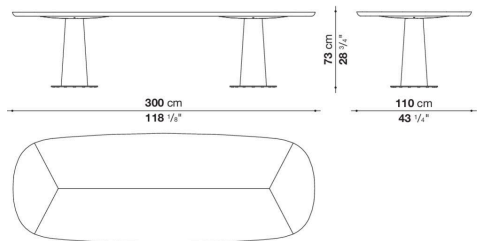

TKL350

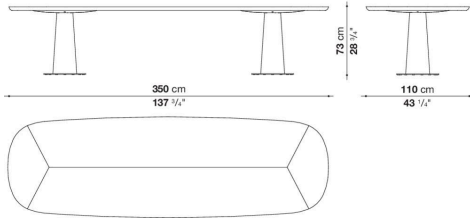

TKL350_MR

